

Schematic Detail of BPT600 System with 150mm Outlet

SPECIFICATIONS

Material	12mm MDPE
Chamber Volume	330 litres
Grate	Class B/ Galvanised
Treated Flow Rate	5 Litres/sec
Maximum Flow Rate	20 Litres/sec
Solids Capacity	50 litres
Silt Basket Capacity	50 litres
Sediment Removal	>0.3mm
Hydrocarbon Capture	>95%
Retention at Byflow rate	100%

Available Options

225mm Stormwater Outlet
Class 'D' Grate
Risers - for connections from other sources, eg. Grated Drain

Note: Inverts will change.
Request details if required.

PROCESS DETAILS

The Fox Model BPT600 is a baffled pollutant trap with a high flow by-pass. It is designed for use in open areas where trash and other debris cannot be controlled and a potential for minor quantities of hydrocarbons exists. The unit has a controlled flow rate through the silt basket where trash and silt are removed. Runoff then enters the main chamber and exits via the baffle, retaining minor quantities of hydrocarbons that may be present. If the rain intensity exceeds the treatable flow rate the high flow by-pass allows excess runoff to exit directly via the baffle. The Fox BPT600 has an efficiency of greater than 99% for the capture and retention of silts and solids smaller than 3mm.

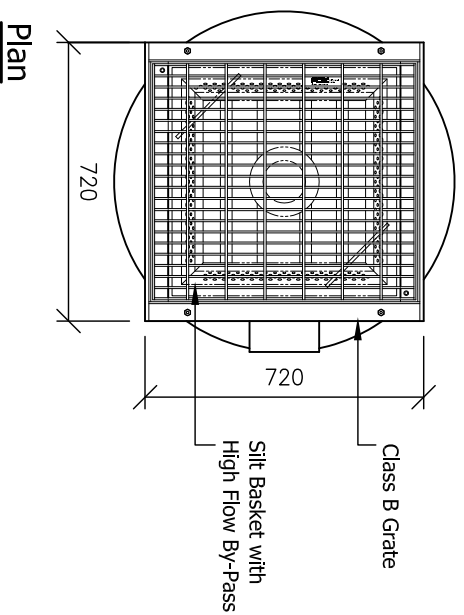

Plan

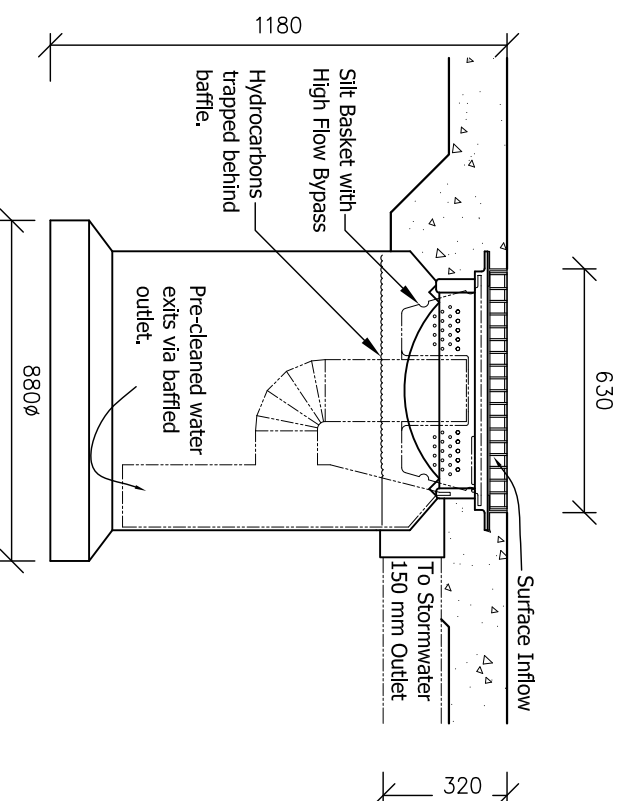

Elevation

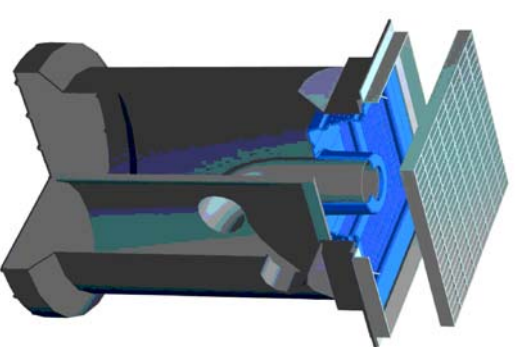

This is a schematic representation only. Slab size and gradient to engineers details as arranged by customer. All plumbing and electrical connections to be installed by certified tradesmen in accordance with relative authorities requirements. Tradesmen to be engaged by the purchaser. System to be approved by relative Local Authorities before Installation.
This Drawing and design is the Property of Fox Environmental Systems Pty Ltd. It must not be used for any other purpose than that for which it was issued.

Project
System Specifications

Drawing Title
BPT600/150

Drawn by:	J.F.S
Date:	13/01/2010
Scale:	As Specified
Drawing No:	A4-SPEC-R-1016