

Specification FX6000SS-D Oil/ Water Separator

SPECIFICATIONS

Material - Tank	2.0mm 304 stainless steel
Lid	1.6mm 304 stainless steel
Stand	40mm SHS stainless steel
Maximum flow rate	6000 litres per hour
Actual flow rate	4200 litres per hour
Pump type	ASM DS 38
Separation process	Enhanced gravity
Coalescing medium	Vertical tube pack
Weight (empty)	245kg
Weight (full)	1170kg
Volume	950 litres net
Inlet	80mm BSP Female
Outlet	100mm BSP Female
Gate Valve	2x40mm BSP Male

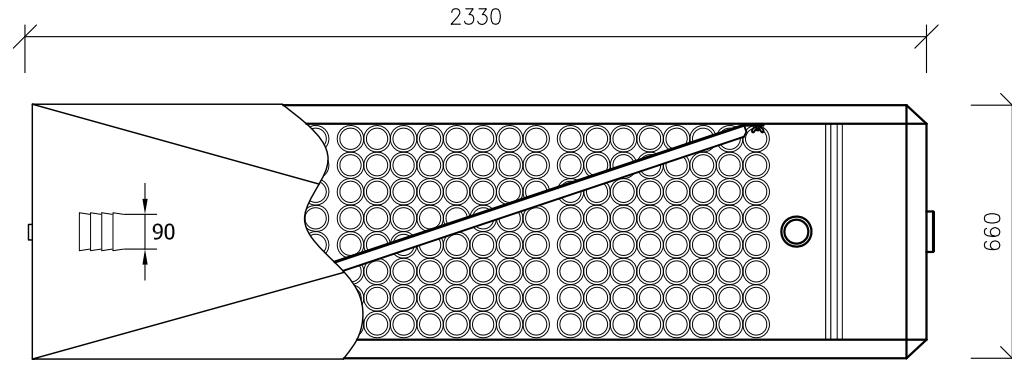

Note:
For marine applications Separator can be supplied in 316 or 445m Grade Stainless Steel.

VTC Filter pack Specification

Tube	55 mm Dia.
Block Size x 3	550x550x500mm
Volume	0.45 m ³
Surface Area	90 m ²

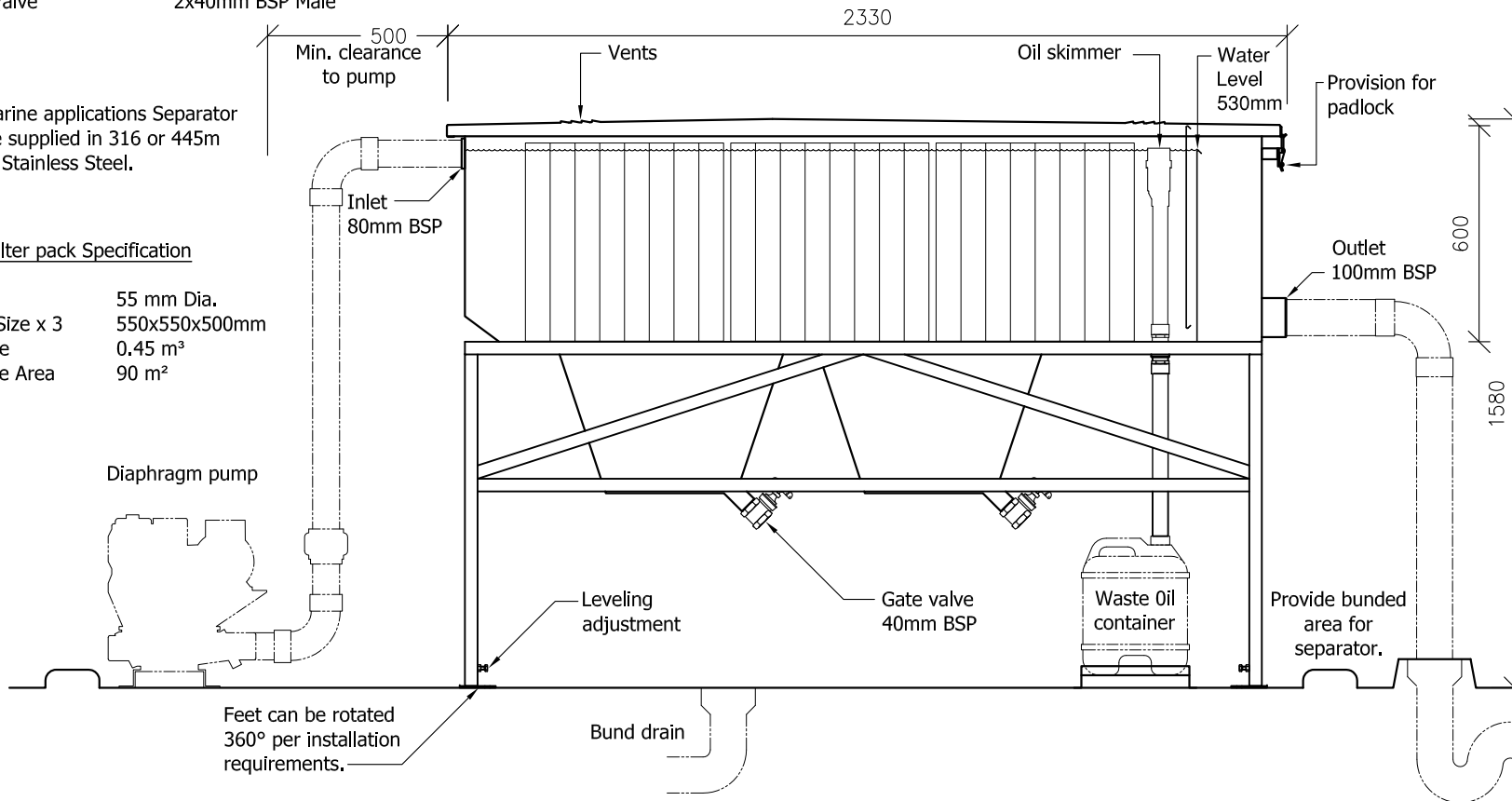

This is a schematic representation only. Slab size and gradient to engineers details as arranged by customer. All plumbing and electrical connections to be installed by certified tradesmen in accordance with relative authorities requirements. Tradesmen to be engaged by the purchaser. System to be approved by relative Local Authorities before Installation.

This Drawing and design is the Property of Fox Environmental Systems Pty Ltd. It must not be used for any other purpose than that for which it was issued.

Project
Fox FX6000SS Specifications

Drawing Title
FX6000SS-D Oil/ Water Separator

Drawn by:	JFS
Date:	01/11/2010
Scale:	1:20
Drawing No:	A4-SPEC-1023