

Detail of SCS600 System

Model: SCS600

Manufacture: Fox Environmental Systems

Max Working Pressure: 170 PSI

Grate Class: Class B Heavy Duty

RPZ: Compliant with ASSE1013

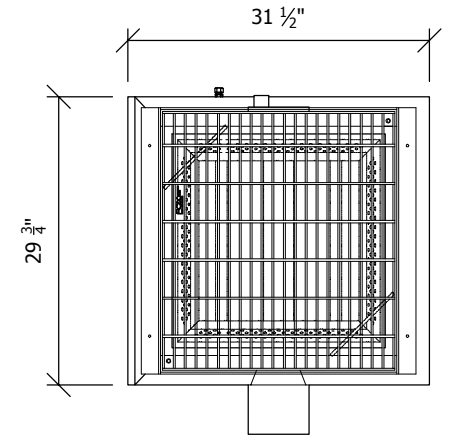

Plan View

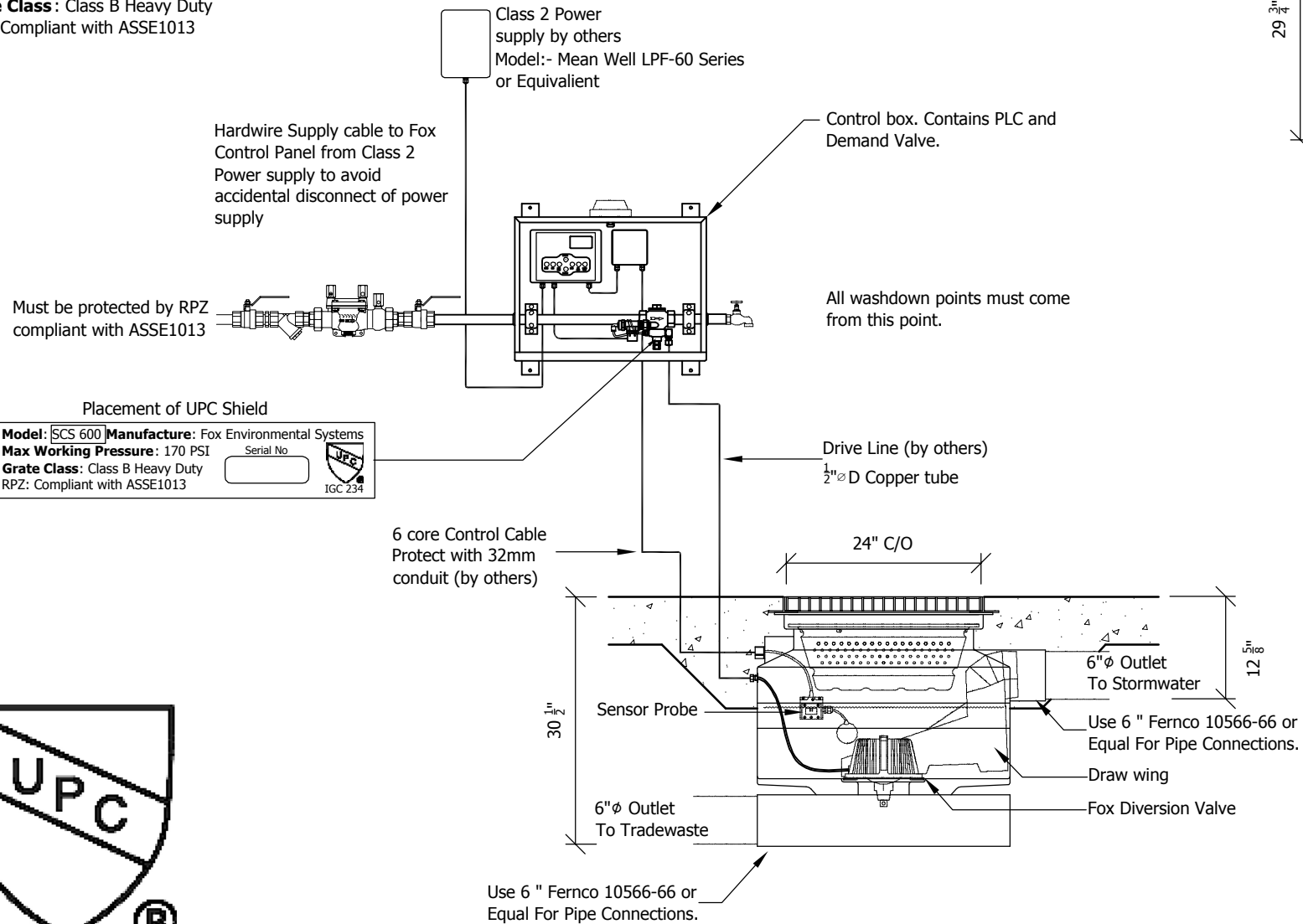

IAPMO IGC 234 2016
File Number 10153



Project	IAPMO
Drawing Title	SCS600 System

Drawn by:	J.F.S
Date:	15/08/2016
Scale:	1:20
Drawing No:	A4-SPEC-1010