

# Washdown Diversion Systems FOR ALL UNROOFED WASHDOWN AREAS

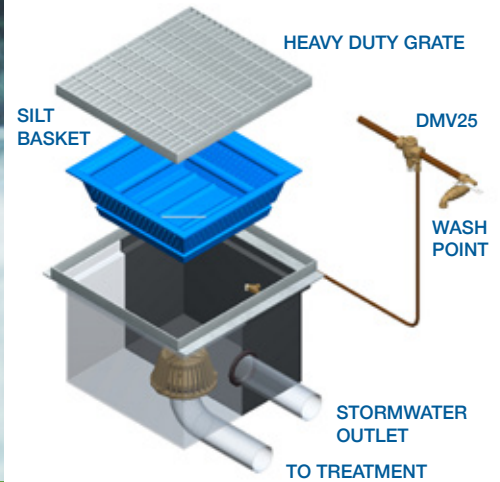

## MODEL DD600



FOX DEMAND VALVE  
DMV25



FOX DIVERSION VALVE  
DMV150

## MODEL DD400

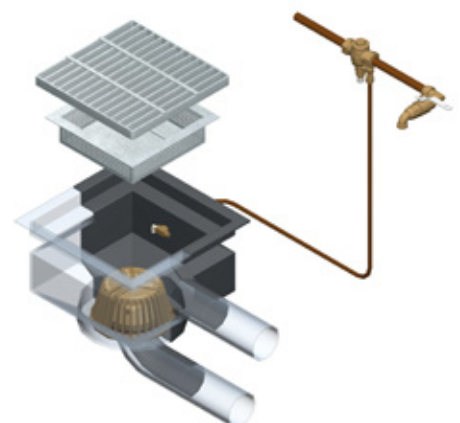

## DEMAND DRIVEN SYSTEMS

For over thirty years Fox has been developing and manufacturing a range of stormwater diversion systems designed to protect industries whose operations may cause potential harm to the stormwater course and the environment.

A Fox diversion system is the most effective control device for any unroofed washdown area automatically diverting wash water as well as the first flush (if required) to treatment while allowing unpolluted rain water to enter the stormwater network.

At the heart of a Fox diversion system is a Fox Demand valve

which is fitted inline before the wash point and the Fox Diversion Valve which comes fitted in a range of varied pit sizes or can be set up on 10mm Marine grade Aluminium plate to suit custom formed concrete pits.

A hydraulic signal is sent from the demand valve to the diversion valve when washdown commences, automatically opening the diversion valve protecting the environment from contaminated washwater.

At the end of the washdown operation the diversion valve will automatically close, allowing rainwater to exit through the stormwater outlet, this diversion eliminates the cost of treating clean rain water.

## APPLICATIONS

- Bin wash facility
- Car wash facility
- Machinery washdown
- Mechanical workshops
- Parts washing
- Marinas & Slipways
- Truck washdown
- Rail yards
- Vehicle dealerships
- Kennels
- All wash applications

A Fox Diversion System eliminates expensive roofing creating a more effective outdoor wash area. The systems are fully automatic and are approved under the Australian Watermark and IAPMO to fulfil local authorities requirements.

